



## AT86 Series - ATSHIELD TT

# Combined technology against direct lightning strikes

ATSHIELD TT

### AT86 SERIES - ATSHIELD TT

#### AT8603 ATSHIELD TT 380T:

protection of both line and neutral to ground for 380V<sub>AC</sub> three phase lines

#### AT8604 ATSHIELD TT 220T:

protection of both line and neutral to ground for 220V<sub>AC</sub> three phase lines

Efficient and compact protection against transient overvoltages for TT and TNS power supplies systems, using an internal combination of spark gaps and metal oxide varistors.

This combination is connected in such a way that no element in series with the line is needed for the correct coordination of the protection.

This protector combines the best characteristics of both technologies: the **passing residual voltage of the varistors together with the capacity of lightning current absorption of the spark gaps.**

Tested and certified as **Class I** and **II** according to regulations IEC61643-1, EN61643-11. Suitable for **Categories I, II, III** and **IV** equipment according to RBT2002.



- Coordinable with other SPDs such as ATSHOCK, ATSUB and ATCOVER series.
- Short response time.
- Don't produce deflagration.
- Multi-pole protection.
- Their activation causes no interruption in power supply.
- Compact protection.
- Thermodynamic control device and light alarm for each phase.

AT86 Series SPDs have been tested in **official and independent laboratories**, obtaining their characteristics according to relevant standards (shown in the table).

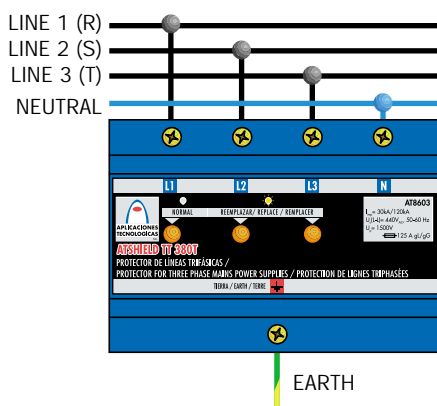

### INSTALLATION

*ATSHIELD TT Surge Protective Devices are to be installed in parallel with the Low Voltage three phase power supply line provided with a neutral.*

*The **power should be disconnected** during the installation of the SPD.*

*Their installation is recommended in main switchboards, where the line enters the building or where big overvoltages can take place.*

*Their installation is recommended in places where direct lightning strikes can occur after the main board and when lines are connected to very sensitive equipment that cannot withstand big overvoltages.*

***Earth connection** is a must. Earthing in all the installation must be bonded either directly or by a spark gap and resistance should be lower than 10Ω. If the indications of this datasheet are not fulfilled during the use or installation of the SPDs, the protection assured by this device could be endangered.*

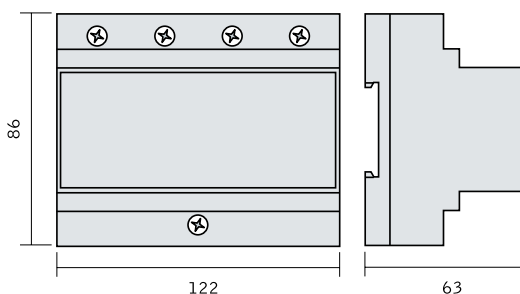



**AT8603 ATSHIELD TT 380T:** protection of both line and neutral to ground for 380V<sub>AC</sub> three phase lines

**AT8604 ATSHIELD TT 220T:** protection of both line and neutral to ground for 220V<sub>AC</sub> three phase lines

Reference	ATSHIELD TT 380T		ATSHIELD TT 220T	
	AT8603		AT8604	
Protection categories according to RBT2002:	I, II, III, IV			
Type of tests according to IEC61643-1, EN61643-11:	Class I and II			
Nominal voltage:	U <sub>n</sub>	380V <sub>AC</sub> (L-L) 220V <sub>AC</sub> (L-N, L-G)	220V <sub>AC</sub> (L-L) 130V <sub>AC</sub> (L-N, L-G)	
Maximum continuous operating voltage:	U <sub>c</sub>	440V <sub>AC</sub> (L-L) 255V <sub>AC</sub> (L-N, L-G)	255V <sub>AC</sub> (L-L) 145V <sub>AC</sub> (L-N, L-G)	
Nominal frequency:		50/60Hz		
Impulse current (10/350μs):	I <sub>imp</sub>	30/120kA		
Specific energy:	W/R	224kJ/Ω		
Nominal discharge current (8/20μs wave):	I <sub>n</sub>	40/160kA		
Level of protection:	U <sub>p</sub>	< 1500V		
Follow current extinguishing capability:	I <sub>r</sub>	50 kA <sub>eff</sub>		
Response time:	t <sub>r</sub>	< 100ns		
Backup fuse <sup>(1)</sup> :		125A gL/gG		
Maximum short-circuit current:		25kA (for maximum fuse)		
SPD location:		Indoor		
Type of connection:		Parallel (one port)		
Mounting method:		Fixed		
Working temperature:	ϑ	-55°C to +85°C		
Dimensions:		122 x 86 x 63mm (7 mod. DIN43880)		
Fixing:		DIN Rail		
Enclosure material:		Polycarbonate		
Enclosure protection:		IP20		
Insulation resistance:		> 10 <sup>14</sup> Ω		
Autoextinguish enclosure:		V-0 type according to UNE-EN 60707 (UL94)		
Connections L/N/G:		Max/Min section multi-stranded: 16 / 45mm <sup>2</sup> (5/1 AWG) Max/Min section single-stranded: 10 / 45mm <sup>2</sup> (7/1 AWG)		

**Certificated tests according to: IEC 61643-1 / EN 61643-11 / IEC 61312-3**

Complies with requirements of: UL 1449

Relevant standards: UNE21186 / NFC 17102 / UNE21185 / IEC61024-1 / IEC61312-3

(1) Needed in cases where there is no equal or less nominal current installed "upstream" from the protector.