



## ATBARRIER Series

ATBARRIER

# Full protection for three-phase power supply lines

### ATBARRIER SERIES

#### AT8114 ATBARRIER MFF 100kA/200kA:

Coordinated protection for single-phase lines with ATSHOCK+ATCOVER

#### AT8125 ATBARRIER MF 100kA/200kA:

Coordinated protection for single-phase lines with ATSHOCK+ATSUB20

#### AT8118 ATBARRIER MM 100kA/200kA:

Coordinated protection for single-phase lines with ATSHOCK+ATSUB40

#### AT8134 ATBARRIER TFF 100kA/400kA:

Coordinated protection for three-phase lines with ATSHOCK+ATCOVER

#### AT8141 ATBARRIER TF 100kA/400kA:

Coordinated protection for three-phase lines with ATSHOCK+ATSUB20

#### AT8121 ATBARRIER TM 100kA/400kA:

Coordinated protection for three-phase lines with ATSHOCK+ATSUB40

**+DIF:** Protection boxes containing not only protection in common mode but also in differential mode (line-neutral)

**+F:** Boxes including backup fuses

**-N:** Lines with no neutral

**M:** medium residual voltage (with ATSUB40)

**F:** low residual voltage (with ATSUB20)

**FF:** very low residual voltage (with ATCOVER)

**ATBARRIER - T F 100kA / 400kA**

**T:** for Three-Phase supply  
**M:** for Single-Phase supply

Discharge Current ( $I_{max}$ ) for one pole

Discharge Current ( $I_{max}$ ) for whole Box

A proper surge protection is only achieved if all the stages are well coordinated. Otherwise the most robust protection will not act, possibly causing the destruction of the most sensitive protectors and even the equipment that they should protect.

For the working of all the protections, they must be separated by at least 10 meters cable. If this were not possible, a decoupling inductor should be installed between the protection stages. ATBARRIER boxes contain all the necessary elements for a coordinated protection.



ATBARRIER boxes are to be installed **in series** with the Low Voltage line, connected to line/s, neutral and ground. **Fuses or circuit breakers must be present** upstream. They will be disconnected during the installation for working security. If this protection does not exist, fuses must be installed in series with the box. Their installation is recommended where direct lightning currents could penetrate and very sensitive equipment is connected, without distance enough for SPD coordination.

The SPDs contained in ATBARRIER and their coordination have been tested in **official, independent laboratories**, obtaining their characteristics according to relevant standards (related in the table): IEC61643-1, EN61643-11 and NF-C-61-0740.

### INSTALLATION

**ATBARRIER** boxes are to be installed **in series** with the Low Voltage line, connected to line/s, neutral and ground. **Fuses or circuit breakers must be present** upstream. They will be disconnected during the installation for working security. If this protection does not exist, fuses must be installed in series with the box.

Their installation is recommended where direct lightning currents could penetrate and very sensitive equipment is connected, without distance enough for SPDs coordination.

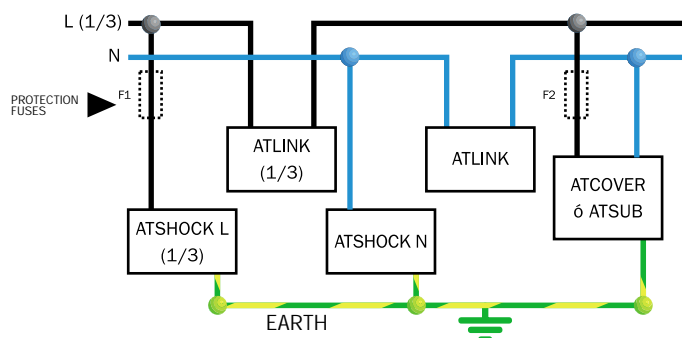

The working current of the line  $I_n$  must be **lower than 63A**.

**Earth connection** is a must. Earthing in all the installation must be bonded either directly or by a spark gap and resistance should be lower than  $10\Omega$ . If the indications of this datasheet are not fulfilled during the use or installation of the SPDs, the protection assured by this device could be endangered.



### AT8114 - ATBARRIER MFF 100kA/200kA:

Full protection for single-phase power supply lines

### ATBARRIER MFF 100kA/200kA

#### AT8114

Reference		
Protection categories according to RBT2002:		I, II, III and IV
Type of tests according to IEC61643-1, EN61643-11:		Class I, II and III
Nominal voltage:	$U_n$	220V <sub>AC</sub> (L-G), 50Hz
Maximum continuous operating voltage:	$U_c$	255V <sub>AC</sub> (L-G), 50Hz
Maximum working current:	$I_n$	63A
Nominal discharge current (8/20 $\mu$ s wave):	$I_n$	50kA / 100kA
Impulse current (10/350 $\mu$ s wave):	$I_{imp}$	100kA / 200kA
Protection level for 8/20 $\mu$ s at $I_n$ :	$U_p(I_n)$	800V
Response time:	$t_r$	< 25ns
Backup fuse <sup>(1)</sup> :		160A gL/gG
Maximum short-circuit current:		50kA/100kA (for maximum fuse)
Dimensions:		460 x 340 x 160 mm
Fixing:		Wall or vertical support
Working temperature:	$\vartheta$	-55°C to +85°C
Enclosure material:		Autoextinguishing, isolating
Fire resistance:		650°C according to IEC 695-2-1
Enclosure protection:		IP65 according to IEC 60.529
Impact protection:		IK09 according to EN 50.102
Connections L/N/G:		Maximum section 45mm <sup>2</sup> (AWG 1)

**Certificated tests according to: IEC 61643-1/BS 6651/EN 61000-4-5/NFC 61-0740/EN 61643-11/IEC 61312-3**

Complies with requirements of: UL 1449

Relevant standards: UNE21186 / NFC 17102 / UNE21185 / IEC61024-1 / IEC61312-3

(1) Needed in cases where there is no equal or less nominal current installed "upstream" from the protector

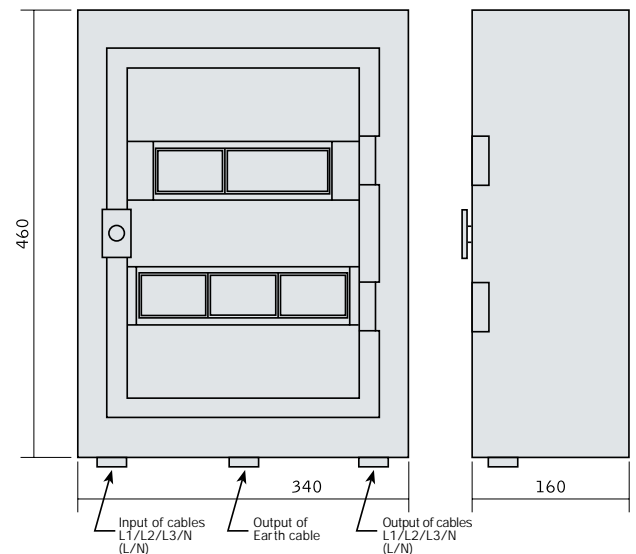
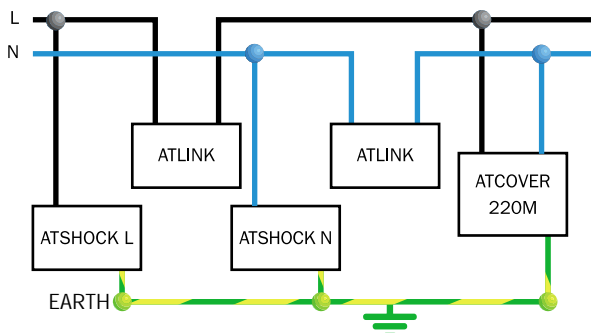



**AT8125 - ATBARRIER MF 100kA/200kA:**

Full protection for single-phase  
power supply lines

**ATBARRIER MF 100kA/200kA**

**AT8125**

Reference		<b>AT8125</b>
Protection categories according to RBT2002:		I, II, III and IV
Type of tests according to IEC61643-1, EN61643-11:		Class I, II and III
Nominal voltage:	$U_n$	380V <sub>AC</sub> (L-G), 50Hz
Maximum continuous operating voltage:	$U_c$	440V <sub>AC</sub> (L-G), 50Hz
Maximum working current:	$I_N$	63A
Nominal discharge current (8/20μs wave):	$I_n$	50kA / 100kA
Impulse current (10/350μs wave):	$I_{imp}$	100kA / 200kA
Protection level for 8/20μs at $I_n$ :	$U_p(I_n)$	1000V
Response time:	$t_r$	< 25ns
Backup fuse <sup>(1)</sup> :		160A gL/gG
Maximum short-circuit current:		50kA/100kA (for maximum fuse)
Dimensions:		460 x 340 x 160 mm
Fixing:		Wall or vertical support
Working temperature:	$\vartheta$	-55°C to +85°C
Enclosure material:		Autoextinguishing, isolating
Fire resistance:		650°C according to IEC 695-2-1
Enclosure protection:		IP65 according to IEC 60.529
Impact protection:		IK09 according to EN 50.102
Connections L/N/G:		Maximum section 45mm <sup>2</sup> (AWG 1)

**Certificated tests according to: IEC 61643-1 / NFC 61-0740/ EN 61643-11 / IEC 61312-3**

Complies with requirements of: UL 1449

Relevant standards: UNE21186 / NFC 17102 / UNE21185 / IEC61024-1 / IEC61312-3

(1) Needed in cases where there is no equal or less nominal current installed "upstream" from the protector

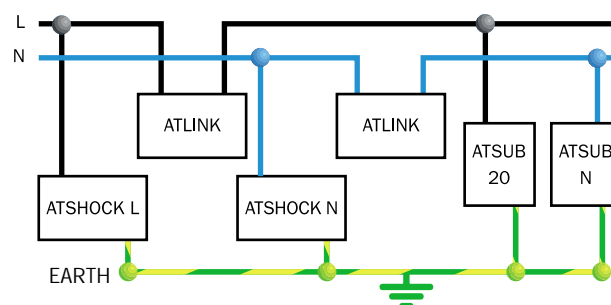
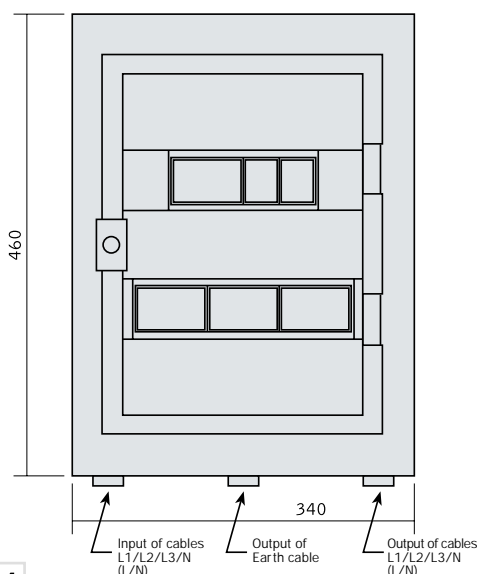

**AT8118 - ATBARRIER MM 100kA/200kA:**

 Full protection for single-phase  
power supply lines

**ATBARRIER MM 100kA/200kA**
**AT8118**

Reference		<b>AT8118</b>
Protection categories according to RBT2002:		I, II, III and IV
Type of tests according to IEC61643-1, EN61643-11:		Class I, II and III
Nominal voltage:	$U_n$	380V <sub>AC</sub> (L-G), 50Hz
Maximum continuous operating voltage:	$U_c$	440V <sub>AC</sub> (L-G), 50Hz
Maximum working current:	$I_n$	63A
Nominal discharge current (8/20 $\mu$ s wave):	$I_n$	50kA / 100kA
Impulse Current (10/350 $\mu$ s wave):	$I_{imp}$	100kA / 200kA
Protection level for 8/20 $\mu$ s at $I_n$ :	$U_p(I_n)$	1200V
Response Time:	$t_r$	< 25ns
Backup fuse <sup>(1)</sup> :		160A gL/gG
Maximum short-circuit current:		50kA/100kA (for maximum fuse)
Dimensions:		460 x 340 x 160 mm
Fixing:		Wall or vertical support
Working Temperature:	$\vartheta$	-55°C to +85°C
Enclosure material:		Autoextinguishing, isolating
Fire resistance:		650°C according to IEC 695-2-1
Enclosure protection:		IP65 according to IEC 60.529
Impact protection:		IK09 according to EN 50.102
Connections L/N/G:		Maximum section 45mm <sup>2</sup> (AWG 1)

**Certificated tests according to: IEC 61643-1 / NFC 61-0740/ EN 61643-11 / IEC 61312-3**

Complies with requirements of: UL 1449

Relevant standards: UNE21186 / NFC 17102 / UNE21185 / IEC61024-1 / IEC61312-3

(1) Needed in cases where there is no equal or less nominal current installed "upstream" from the protector

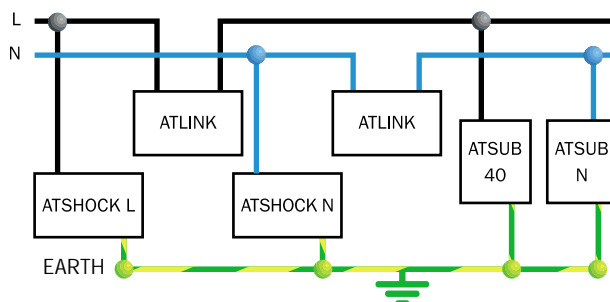
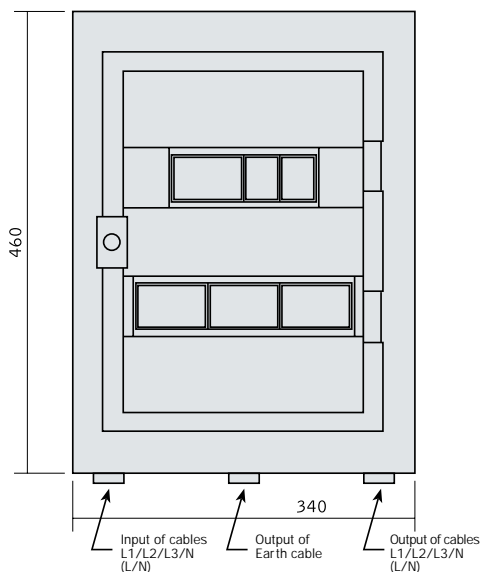



**AT8134 - ATBARRIER TFF 100kA/400kA:**

Full protection for three-phase power supply lines

**ATBARRIER TFF 100kA/400kA**

**AT8134**

Reference		<b>AT8134</b>
Protection categories according to RBT2002:		I, II, III and IV
Type of tests according to IEC61643-1, EN61643-11:		Class I, II and III
Nominal voltage:	$U_n$	380V <sub>AC</sub> (L-L), 50Hz
Maximum continuous operating voltage:	$U_c$	440V <sub>AC</sub> (L-L), 50Hz
Maximum working current:	$I_N$	63A
Nominal discharge current (8/20μs wave):	$I_n$	50kA / 200kA
Impulse current (10/350μs wave):	$I_{imp}$	100kA / 400kA
Protection level for 8/20μs at $I_n$ :	$U_p(I_n)$	800V
Response Time:	$t_r$	< 25ns
Backup fuse <sup>(1)</sup> :		160A gL/gG
Maximum short-circuit current:		50kA/200kA (for maximum fuse)
Dimensions:		610 x 448 x 160 mm
Fixing:		Wall or vertical support
Working temperature:	$\vartheta$	-55°C to +85°C
Enclosure material:		Autoextinguishing, isolating
Fire resistance:		650°C according to IEC 695-2-1
Enclosure protection:		IP65 according to IEC 60.529
Impact protection:		IK09 according to EN 50.102
Connections L/N/G:		Maximum section 45mm <sup>2</sup> (AWG 1)

**Certificated tests according to: IEC 61643-1/ BS 6651/EN 61000-4-5/NFC 61-0740/EN 61643-11/IEC 61312-3**

Complies with requirements of: UL 1449

Relevant standards: UNE21186 / NFC 17102 / UNE21185 / IEC61024-1 / IEC61312-3

(1) Needed in cases where there is no equal or less nominal current installed "upstream" from the protector

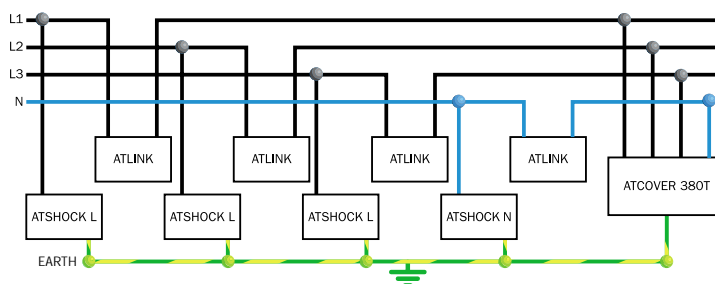
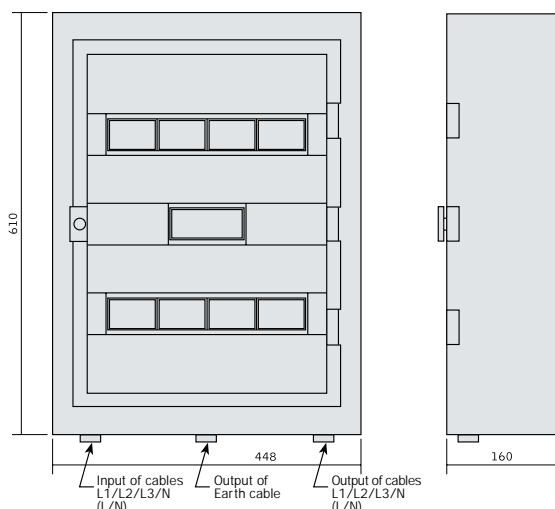

**AT8141 - ATBARRIER TF 100kA/400kA:**

Full protection for three-phase power supply lines

Reference		<b>ATBARRIER TF 100kA/400kA</b>	
		<b>AT8141</b>	
Protection categories according to RBT2002:		I, II, III and IV	
Type of tests according to IEC61643-1, EN61643-11:		Class I, II and III	
Nominal voltage:	$U_n$	380V <sub>AC</sub> (L-G), 50Hz	
Maximum continuous operating voltage:	$U_c$	440V <sub>AC</sub> (L-G), 50Hz	
Maximum working current:	$I_n$	63A	
Nominal discharge current (8/20 $\mu$ s wave):	$I_n$	50kA / 200kA	
Impulse current (10/350 $\mu$ s wave):	$I_{imp}$	100kA / 400kA	
Protection level for 8/20 $\mu$ s at $I_n$ :	$U_p(I_n)$	1000V	
Response time:	$t_r$	< 25ns	
Backup fuse <sup>(1)</sup> :		160A gL/gG	
Maximum short-circuit current:		50kA/200kA (for maximum fuse)	
Dimensions:		610 x 448 x 160 mm	
Fixing:		Wall or vertical support	
Working temperature:	$\varnothing$	-55°C to +85°C	
Enclosure material:		Autoextinguishing, isolating	
Fire resistance:		650°C according to IEC 695-2-1	
Enclosure protection:		IP65 according to IEC 60.529	
Impact protection:		IK09 according to EN 50.102	
Connections L/N/G:		Maximum section 45mm <sup>2</sup> (AGW 1)	

**Certificated tests according to: IEC 61643-1 / NFC 61-0740 / EN 61643-11 / IEC 61312-3**

Complies with requirements of: UL 1449

Relevant standards: UNE21186 / NFC 17102 / UNE21185 / IEC61024-1 / IEC61312-3

(1) Needed in cases where there is no equal or less nominal current installed "upstream" from the protector

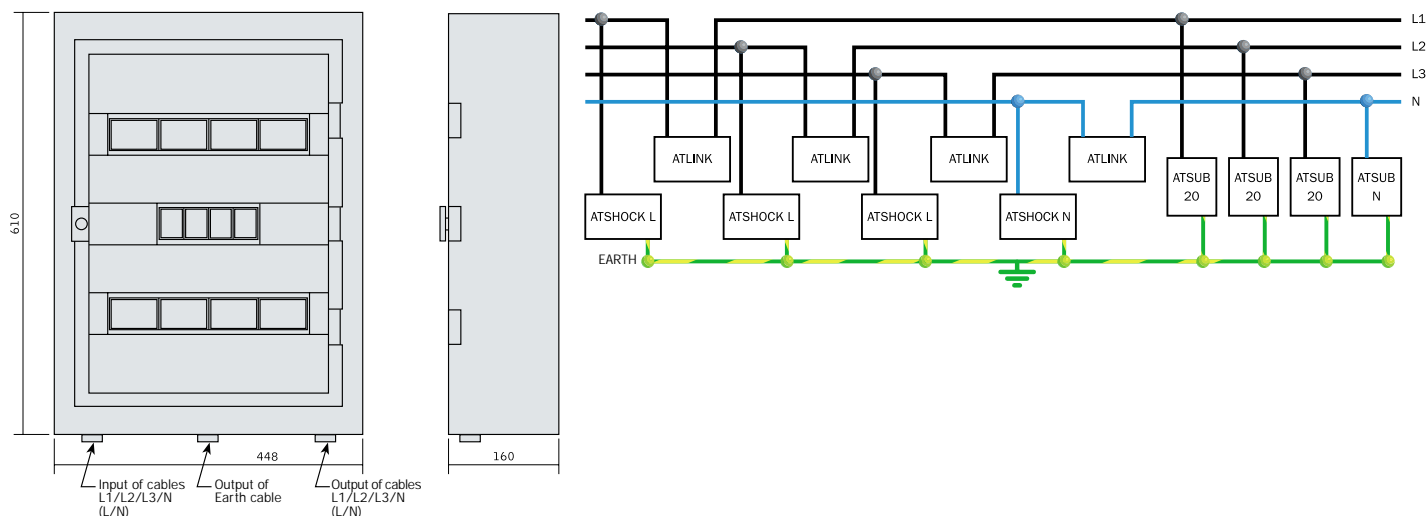



**AT8121 - ATBARRIER TM 100kA/400kA:**  
Full protection for three-phase  
power supply lines

**ATBARRIER TM 100kA/400kA**

**AT8121**

Reference		I, II, III and IV
Protection categories according to RBT2002:		Class I, II and III
Type of tests according to IEC61643-1, EN61643-11:		380V <sub>AC</sub> (L-G), 50Hz
Nominal voltage:	U <sub>n</sub>	440V <sub>AC</sub> (L-G), 50Hz
Maximum continuous operating voltage:	U <sub>c</sub>	63A
Maximum working current:	I <sub>N</sub>	50kA / 200kA
Nominal discharge current (8/20μs wave):	I <sub>n</sub>	100kA / 400kA
Impulse current (10/350μs wave):	I <sub>imp</sub>	1200V
Protection level for 8/20μs at I <sub>n</sub> :	U <sub>p</sub> (I <sub>n</sub> )	< 25ns
Response time:	t <sub>r</sub>	160A gL/gG
Backup fuse <sup>(1)</sup> :		50kA/200kA (for maximum fuse)
Maximum short-circuit current:		610 x 448 x 160 mm
Dimensions:		Wall or vertical support
Fixing:		-55°C to +85°C
Working temperature:	θ	Autoextinguishing, isolating
Enclosure material:		650°C according to IEC 695-2-1
Fire resistance:		IP65 according to IEC 60.529
Enclosure protection:		IK09 according to EN 50.102
Impact protection:		Maximum section 45mm <sup>2</sup> (AWG 1)
Connections L/N/G:		

**Certificated tests according to: IEC 61643-1 / NFC 61-0740 / EN 61643-11 / IEC 61312-3**

Complies with requirements of: UL 1449

Relevant standards: UNE21186 / NFC 17102 / UNE21185 / IEC61024-1 / IEC61312-3

(1) Needed in cases where there is no equal or less nominal current installed "upstream" from the protector

