

Series AT81M - ATCOVER Single-Phase

ATCOVER M

Single-phase protector for power supply lines

Efficient protection against transient overvoltages in a single phase power supply line in only one device. Medium and low internal coordination protection stages, recommended in Regulation of Low Voltages (RBT2002 ITC23).

Tested and certified as **Class I, II and III** according to regulations IEC61643-1, EN61643-11. Suitable for **Categories I, II, III and IV** equipment according to RBT2002.

- Discharge takes place in an internal encapsulated element, with no external flash. without affecting the normal working of the line and without leakage.
- Coordinable with other SPDs such as ATSHOCK, ATSHIELD and ATSUB series.
- Both common and differential protection for the three lines and the neutral.
- data loss and other inconvenients for the user.
- Low residual voltage.
- With remote control and light alarm.
- Robust connectors, suitable for all type of connection.

ATCOVER SPDs have been tested in **official, independent laboratories**, obtaining their characteristics according to relevant standards (related in the table).

INSTALLATION

ATCOVER Surge Protective Devices are to be installed **in parallel** with the Low Voltage supply line, connected to line/s, neutral and earth.

The **power should be disconnected** during the installation of the SPD.

ATCOVERs can be installed as single protection or in combination with other protectors that withstand higher discharge currents. In this case, it is necessary that both are separated by at least 10 meter cable or, if this is not possible, by a decoupling inductor ATLINK, in order to achieve a **correct coordination** between them.

Their installation is recommended in:

- Main switchboard.
- Secondary boards supplying sensitive systems.
- Power supply of important equipment such as UPSs, PLCs, etc.

Earth connection is a must. Earthing in all the installation must be bonded either directly or by a spark gap and resistance should be lower than 10Ω . If the indications of this datasheet are not fulfilled during the use or installation of the SPDs, the protection assured by this device could be endangered.

AT81M SERIES Single-phase ATCOVER

AT8112 ATCOVER 220M:
single phase, 220V_{AC} line

AT8111 ATCOVER 130M:
single phase, 130V_{AC} line

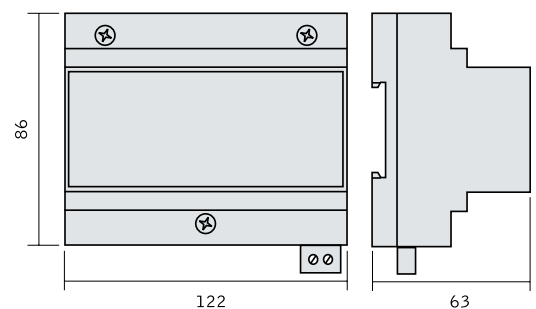
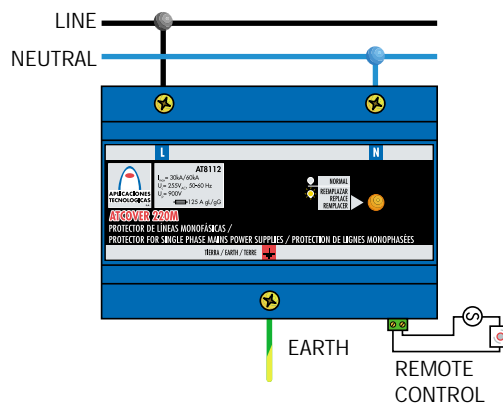

AT8112 ATCOVER 220M:

 single phase, 220V_{AC} line

AT8111 ATCOVER 130M:

 single phase, 130V_{AC} line

Reference	ATCOVER 220M		ATCOVER 130M	
	AT8112		AT8111	
Protection categories according to RBT2002:	I, II, III, IV			
Nominal voltage:	U _n	220V _{AC} (L-N, L-G)	130V _{AC} (L-N, L-G)	
Maximum continuous operating voltage:	U _c	255V _{AC} (L-N, L-G)	145V _{AC} (L-N, L-G)	
Nominal frequency:	50/60Hz			
Nominal discharge current (8/20μs wave):	I _n	10kA / 20kA	10kA / 20kA	
Maximum discharge current (8/20μs wave):	I _{max}	30kA / 60kA	30kA / 60kA	
Impulse current (10/350μs wave):	I _{imp}	6kA / 12kA	6kA / 12kA	
Protection level (1,2/50μs): L - N, L(N) - G	U _p	600V	500V	
Protection level at I _n (8/20μs): L - N, L(N) - G	U _p (I _n)	900V	700V	
Residual voltage with combination wave 6kV/3kA (L-N, L-E): U _{o.c.}		800V	470V	
Response time:	t _r	< 25ns		
Backup fuse ⁽¹⁾ :		125A gL/gG		
Maximum short-circuit current:		25kA (for maximum fuse)		
SPD location:		Indoor		
Type of connection:		Parallel (one port)		
Mounting method:		Fixed		
Working temperature:	ϑ	-55°C to +85°C		
Dimensions:		122 x 86 x 63mm (7 mod. DIN43880)		
Fixing:		DIN Rail		
Enclosure material:		Polycarbonate		
Enclosure protection:		IP20		
Insulation Resistance:		> 10 ¹⁴ Ω		
Autoextinguish enclosure:		V-0 type according to UNE-EN 60707 (UL94)		
Connections L/N/G:		Max/Min section multi-stranded: 16 / 45mm ² (5/1 AWG) Max/Min section single-stranded: 4 / 45mm ² (11/1 AWG)		
Open, voltage-free contact for the remote control				
Connection:		Maximum section single-stranded / multi-stranded: 1,5mm ²		
Contact output:		Normally open		
Working voltage:		250V _{AC} (Maximum working voltage of the alarm supply)		
Maximum current:		2A (Maximum current of the alarm supply)		

Certificated tests according to: IEC 61643-1/BS 6651/EN 61000-4-5/NFC 61-0740/EN 61643-11/IEC 61312-3

Complies with requirements of: UL 1449

Relevant standards: UNE21186 / NFC 17102 / UNE21185 / IEC61024-1 / IEC61312-3

(1) Needed in cases where there is no equal or less nominal current installed "upstream" from the protector.